

LDR6282 USB Type-C PD Controller

REV1.2

Document History

REV1.0	Initial Release	2018-09-03
REV1.1	PIN29/30/31/32 Redefine	2019.02.28
REV1.2	PIN13/16/17/18/19/23/24/25/26/29/30 Redefine	2019.09.30

Contents

1. General Description.....	3
1.1. Features.....	3
1.2. Applications.....	4
1.3. Pin-outs	4
2. Upgrade Function	6
3. Electrical Characteristics.....	7
3.1. Absolute Maximum Ratings	7
3.2. Normal Operating Conditions	7
3.3. ESD Characteristics.....	7
4. Package Dimension	8

1. General Description

LDR6282 is a dual port USB Type-C controller with Display Port™ Alternate mode, especially designed for USB PD Docking Stations with video output. LDR6282 is able to work as dual-role device (Provider or Consumer). LDR6282 provides a complete USB Type-C and USB-Power Delivery port control solution for notebooks, dongles, monitors, Hubs and docking stations.

LDR6282 can perform DP Alt-mode video out functionality and simultaneously enable charging connected PD host once external power is detected. LDR6282's Device Policy Manager could negotiate power profiles with PD engine on Type-C wall adapter (source) and PD engine on connected PD host (sink) then enable power charge-through. Charging dead battery mode is supported as well.

The GPIO pins are available for port power detection, power discharge control, power switch control, data switch control, or other special application usage.

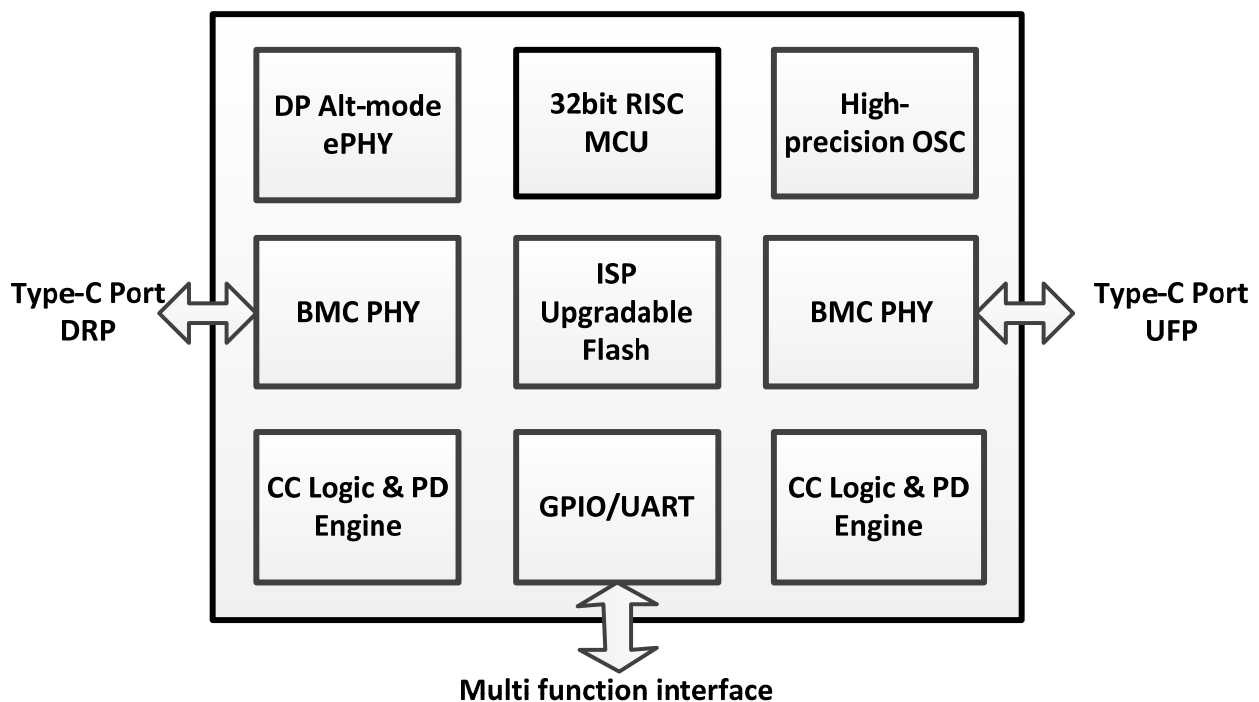

Figure 1. LDR6282 Block Diagram

1.1. Features

- ◇ USB Type-C Spec Rev1.3 compatible

- ◇ USB PD Spec Rev3.0 compatible
- ◇ Support upgrade firmware through APP on the computer
- ◇ Support dead battery mode
- ◇ Support all standard power profiles
- ◇ Support Power Role Swap
- ◇ Support Data Swap to SRC/UFP Role
- ◇ Support Display Port™ Alt mode
- ◇ Temperature range: -40 °C up to 85 °C
- ◇ Available in QFN-32 5x5 Package

1.2. Applications

- ◇ Type-C PD Hub
- ◇ Type-C Multi-function docks
- ◇ Type-C TV, monitor, and video adapters

1.3. Pin-outs

1.3.1. LDR6282 Pin-out Diagram

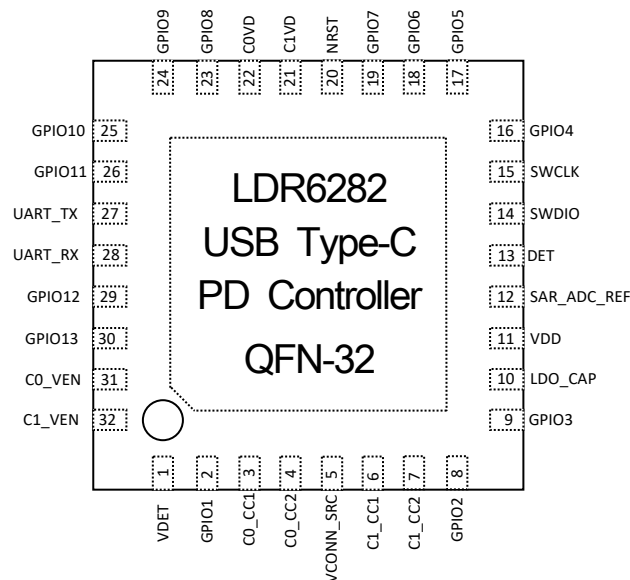

Figure 2. LDR6282 Pin-out

1.3.2. LDR6282 Pin-out Description

Pin No.	Name	Type	Description
---------	------	------	-------------

1	VDET	I	VBUS voltage detect
2	GPI01	I/O	General purpose input output pin
3	C0_CC1	I/O	Configure channel1 of C0 port
4	C0_CC2	I/O	Configure channel2 of C0 port
5	VCONN_SRC	P	VCONN source
6	C1_CC1	I/O	Configure channel1 of C1 port
7	C1_CC2	I/O	Configure channel2 of C1 port
8	GPI02	I/O	General purpose input output pin
9	GPI03	I/O	General purpose input output pin
10	LDO_CAP	0	LDO output pin, connect to 4.7uf capacitance
11	VDD	P	Power supply
12	SAR_ADC_REF	0	Reference voltage of SAR_ADC output, connect to 1uf capacitance
13	I2C_SCL	I/O	I2C Clock
14	SWDIO	I/O	SWD data signal
15	SWCLK	I	SWD clock signal
16	DET	I	Detect pin, if a high level is detected, C0 port will inform the device to output the DP ¹ signal
17	I2C_SDA	I/O	I2C Data
18	GPI04	I/O	General purpose input output pin
19	GPI05	I/O	General purpose input output pin
20	NRST	I/O	Reset pin
21	C1VD	I	C1 port VBUS detect
22	C0VD	I	C0 port VBUS detect
23	GPI06	I/O	General purpose input output pin
24	GPI07	I/O	General purpose input output pin
25	GPI08	I/O	General purpose input output pin
26	GPI09	I/O	General purpose input output pin

27	UART_TX	O	UART transmit signal
28	UART_RX	I	UART receive signal
29	GPIO10	O	General purpose input output pin
30	GPIO11	O	General purpose input output pin
31	C0_VEN	I/O	C0 port VBUS enable
32	C1_VEN	I/O	C1 port VBUS enable
PAD	PAD	G	Ground

Type: P-Power; G-Ground; I-Input; O-Output; I/O-Input / Output.

DP: Display Port™.

2. Upgrade Function

LDR6282 can update the firmware to upgrade the functions through the APP on computer.

There are two pins for LDR6282 to update the firmware.

- ◇ UART_RX : The receiving pin of serial port
- ◇ UART_TX : The sending pin of serial port

The baud rate of serial port is fixed at 19200 bps.

3. Electrical Characteristics

3.1. Absolute Maximum Ratings

Parameter	Description	Min/Max	Unit
VDD	Power supply	-0.3/6	V
V _I	Voltage input	-0.3/6	V
V _O	Voltage output	-0.3/6	V
T _a	Operating temperature	-40/85	°C
T _{stg}	Storage temperature	-55/150	°C

3.2. Normal Operating Conditions

Parameter	Description	Min	Typ	Max	Unit
VCC	Power supply	2.5	5	5.5	V
T _a	Storage temperature	-40	25	85	°C

3.3. ESD Characteristics

Parameter	Description	Range	Unit
V _{ESD}	Human body model ESD	± 2000	V
	Machine model ESD	± 1000	V

4. Package Dimension

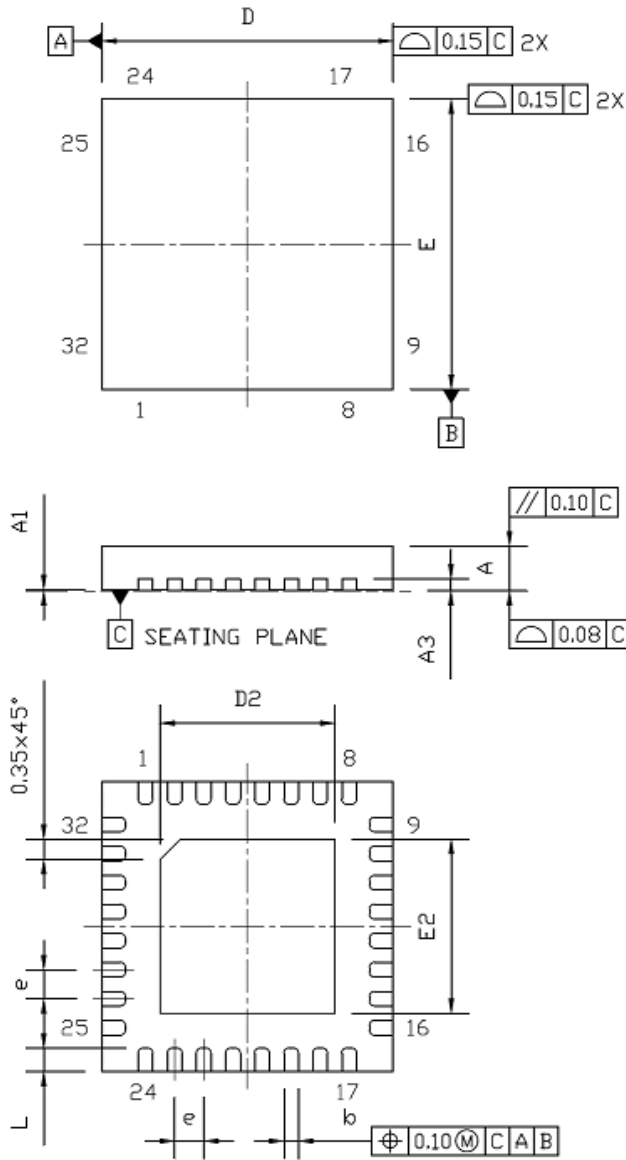

SYMBOL	DIMENSION MM (MIL)		
	MIN.	NOM.	MAX.
A	0.70 (27.6)	0.75 (29.5)	0.80 (31.5)
A1	---	0.02 (0.8)	0.05 (2.0)
A3	0.203 (8.0) REF		
b	0.18 (7.1)	0.25 (9.8)	0.30 (11.8)
D	5.00 (196.9) BSC		
D2	2.60 (102.4)	3.00 (118.1)	3.30 (129.9)
E	5.00 (196.9) BSC		
E2	2.60 (102.4)	3.00 (118.1)	3.30 (129.9)
e	0.50 (19.7) BSC		
L	0.30 (11.8)	0.40 (15.7)	0.50 (19.7)

NOTE: 1. REFER TO JEDEC STD. MO-220
2. ALL DIMENSIONS IN MILLIMETERS.